



**DUKERS**  
Quality Commercial Refrigeration



## REACH IN FREEZER

D28AF

Top Mounted / Solid Door













### **i** TECHNICAL SPECIFICATIONS

Voltage/Frequency 115V/60Hz  
Refrigerant R290  
Type of Defrost Automatic  
Interior Material Stainless Steel  
Exterior Material Stainless Steel  
Temperature Range °F 0 ~ -8°F  
Compressor Power (HP) 3/4  
Nema Config. NEMA5-15P



## PRODUCT FEATURES

-  Equipped with Locking Doors
-  The compressor is mounted in the top and placed in the coolest possible area; this makes it easily accessible for servicing.
-  Digital temperature controls with LED display for precise adjustment and automatic defrosting system.
-  Temperatures in the cabinet range from 0 to -8 degrees Fahrenheit
-  Self closing doors with stay open feature.
-  R290 Natural Refrigerant promotes faster cool down and efficient energy consumption.
-  Epoxy coated wire shelves.
-  Stainless steel interior & exterior, sealed interior floors, and rounded cabinet corners for easy cleaning.
-  High quality coated stainless adjustable shelves prevent peel and rust.
-  Lifetime warranty on hinges.
-  Adjustable front locking casters.



## HIGH QUALITY STAINLESS STEEL & ROBUST DESIGN



**DUKERS**

Los Angeles | San Francisco | Dallas  
Houston | Florida | Chicago | New Jersey

 1-800-931-8628

 [info@dukersusa.com](mailto:info@dukersusa.com)

[www.DukersUSA.com](http://www.DukersUSA.com)

# DETAILS & SPECIFICATIONS

## D28AF

Front View

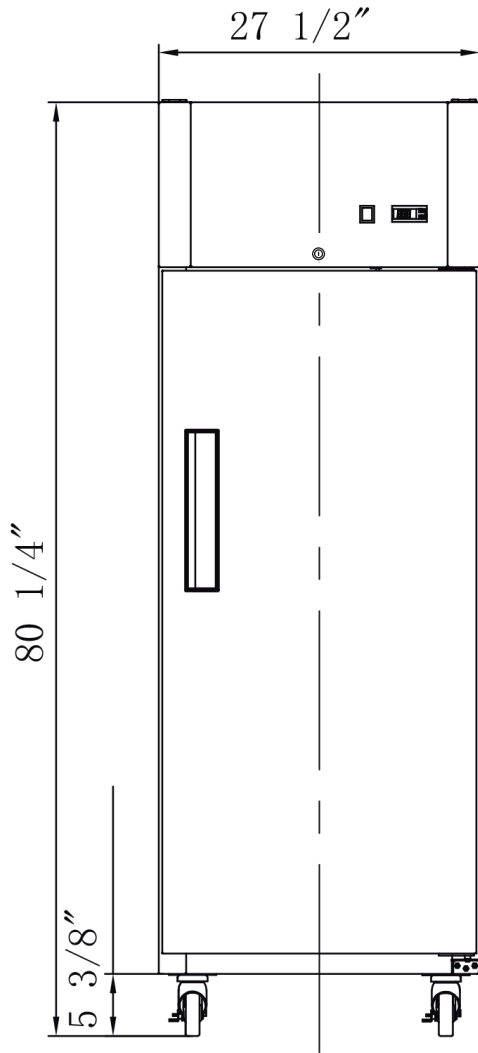

Side View

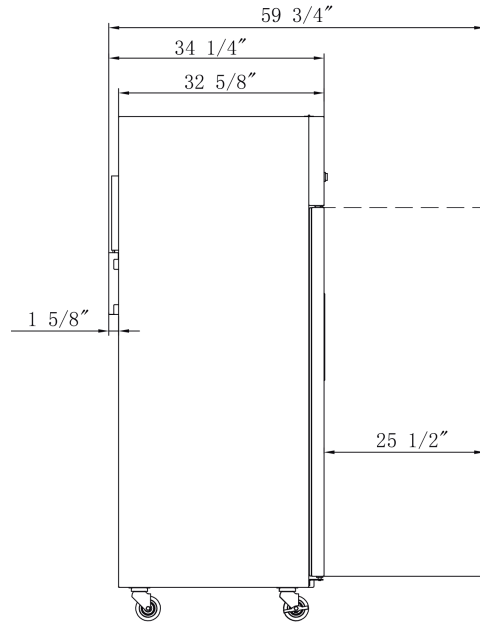

### MODEL D28AF

Rated Voltage	115V
Rated Frequency	60Hz
Total Input Power	750W
Total Current	9.5A
Total Capacity	18.31cu ft
Climatic Category	4-5
Protection Type	I
Design Pressure High Side	300 PSIG
Design Pressure Low Side	150 PSIG
Insulation Blowing Gas	C-Pentane
Refrigerant	R290/4.41 oz

MODEL	EXTERNAL DIMENSION WXDXH (INCHES)	PACKAGING DIMENSION WXDXH (INCHES)	PRODUCT NET WEIGHT	# OF SHELVES	40HQ CONTAINER CERT.
D28AF	27 1/2 x 34 1/4 x 80 1/4	29 1/2 x 35 1/4 x 82 1/4	287 lbs	4	39



Los Angeles | San Francisco | Dallas  
Houston | Florida | Chicago | New Jersey

1-800-931-8628

@ info@dukersusa.com

www.DukersUSA.com