



DUKERS
Quality Commercial Refrigeration













BACK BAR COOLER

MODEL DBB60-S2
Sliding Glass Door



PRODUCT FEATURES

-  Equipped with Locking Doors
-  The side mount compressor structure is placed in an easy access area, provides quick and convenient access.
-  R290 Natural Refrigerant promotes faster cool down and efficient energy consumption.
-  Precision digital temperature controls allow pinpoint accuracy with temperatures from 33-38°F.
-  Stainless steel top, sealed interior floors, and rounded cabinet corners for easy cleaning.
-  Adjustable, heavy-duty epoxy coated shelves.
-  Constructed of commercial-grade body panels in black textured finish to fit all decors and living spaces.
-  Featured in a large size and double pane tempered glass block UV light to safely keep all types of drinks ready to serve.
-  LED interior lighting for bright product display.
-  Optional casters with breaks available upon request for better cleaning and mobility.



TECHNICAL SPECIFICATIONS

| | |
|-----------------------|-----------------------|
| Voltage/Frequency | 115V/60Hz |
| Refrigerant | R290 |
| Type of Defrost | Automatic |
| Interior Material | Stainless Steel |
| Exterior Material | Black Textured Finish |
| Temperature Range °F | 33 ~ 38°F |
| Compressor Power (HP) | 1/3 |
| Nema Config. | NEMA5-15P |



HEAVY-DUTY CABINET FRAME & ROBUST DESIGN



DUKERS

Los Angeles | San Francisco | Dallas
Houston | Florida | Chicago | New Jersey

1-800-931-8628

@ info@dukersusa.com

www.DukersUSA.com

DETAILS & SPECIFICATIONS

BACK BAR COOLER

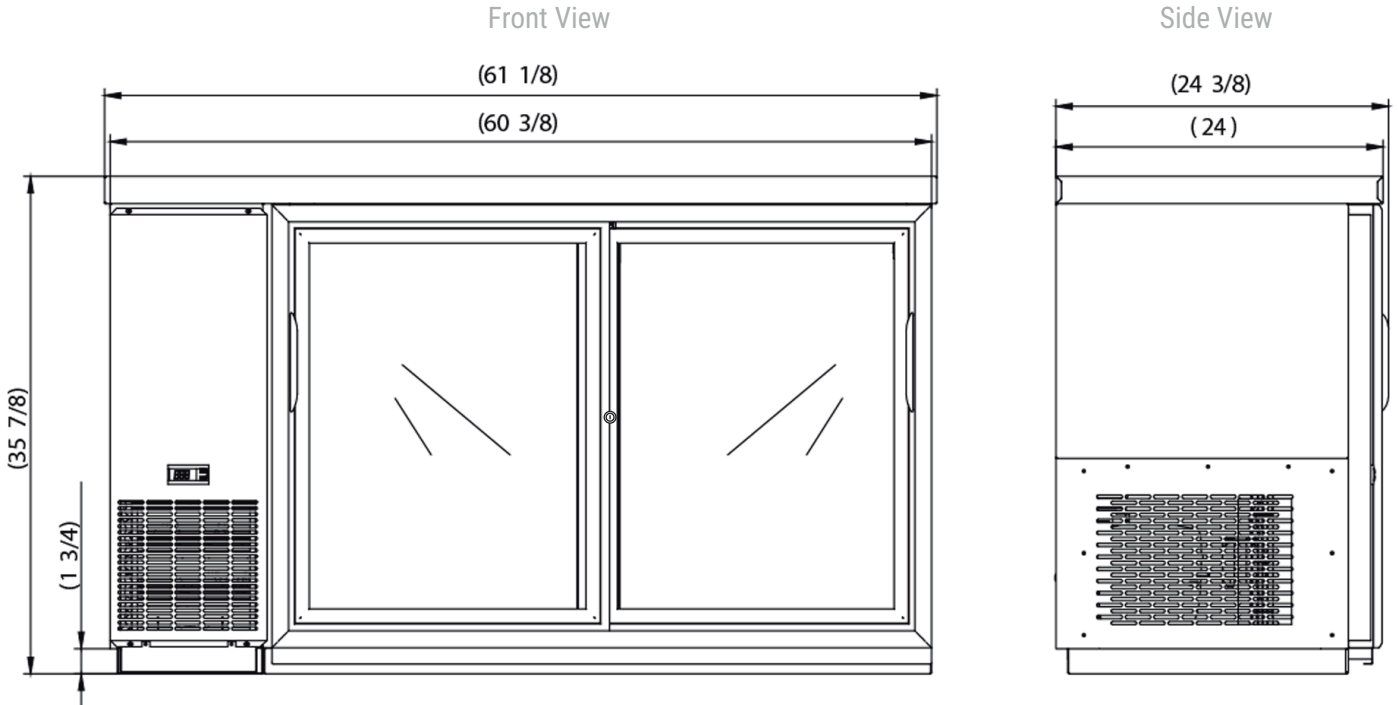

MODEL DBB60-S2

| | |
|---------------------------|--------------|
| Rated Voltage | 115V |
| Rated Frequency | 60Hz |
| Total Input Power | 284W |
| Total Current | 2.66A |
| Total Capacity | 15.24 cu ft |
| Climatic Category | 4-5 |
| Protection Type | I |
| Design Pressure High Side | 385 PSIG |
| Design Pressure Low Side | 150 PSIG |
| Insulation Blowing Gas | C-Pentane |
| Refrigerant | R290/3.53 oz |



| MODEL | EXTERNAL DIMENSION WXDXH (INCHES) | PACKAGING DIMENSION WXDXH (INCHES) | PRODUCT NET WEIGHT | # OF SHELVES | 40FT (PCS) |
|----------|--------------------------------------|---------------------------------------|-----------------------|-----------------|---------------|
| DBB60-S2 | 61 1/8"x24"x35 7/8" | 63 1/2"x26 3/8"x43 1/4" | 220 lbs | 6 | 48 |



Los Angeles | San Francisco | Dallas
Houston | Florida | Chicago | New Jersey

1-800-931-8628

@ info@dukersusa.com

www.DukersUSA.com