



KEGERATOR

MODEL DKB48-M2



PRODUCT FEATURES



The Dukers draft beer system has ample space to withhold different keg of beers. Beer dispenses through a single tube with two handles made of stainless steel to ensure bacterial resistance.



Defrosts automatically to reduce ice buildup, and its evaporator coil is epoxy coated so it won't corrode. Designed with stainless steel construction, the top can be used as a durable workstation that's convenient to wipe clean



Equipped with electronic controls, users can adjust the temperature of the Dukers draft beer cooler from 33 to 38 degrees Fahrenheit.



Heavy-duty casters with brakes are included providing the unit with convenient mobility. Just roll the unit away from the wall.



Magnetic door gasket(s) standard for positive door seal



TECHNICAL SPECIFICATIONS

Voltage/Frequency	110V/60Hz
Refrigerant	R290
Type of Defrost	Automatic
Interior Material	Stainless Steel
Exterior Material	Stainless Steel
Temperature Range °F	33 ~ 38°
Compressor Power (HP)	1/5
Nema Config.	NEMA5-15P



Beer Dispenser



Drip Tray



HIGH QUALITY STAINLESS STEEL & ROBUST DESIGN



Los Angeles | San Francisco | Dallas
Houston | Florida | Chicago | New Jersey

1-800-931-8628

@ info@dukersusa.com

www.DukersUSA.com

DETAILS & SPECIFICATIONS

KEGERATOR

Front View

Top View

Side View

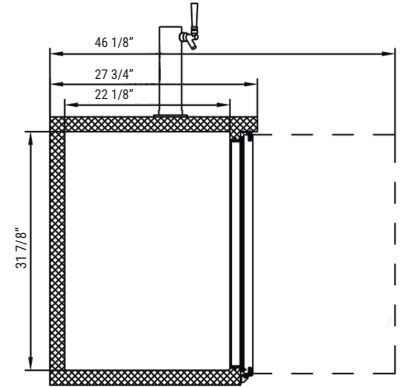
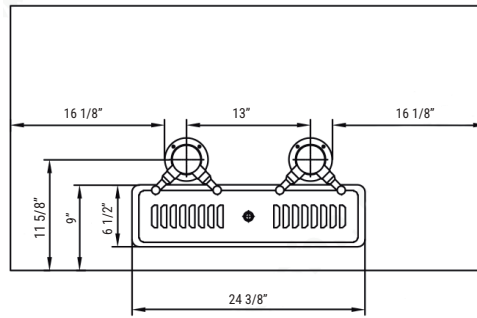
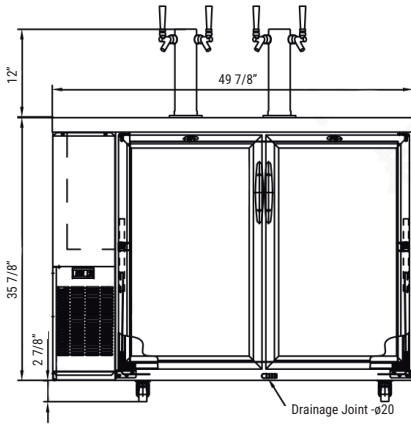

Keg configuration

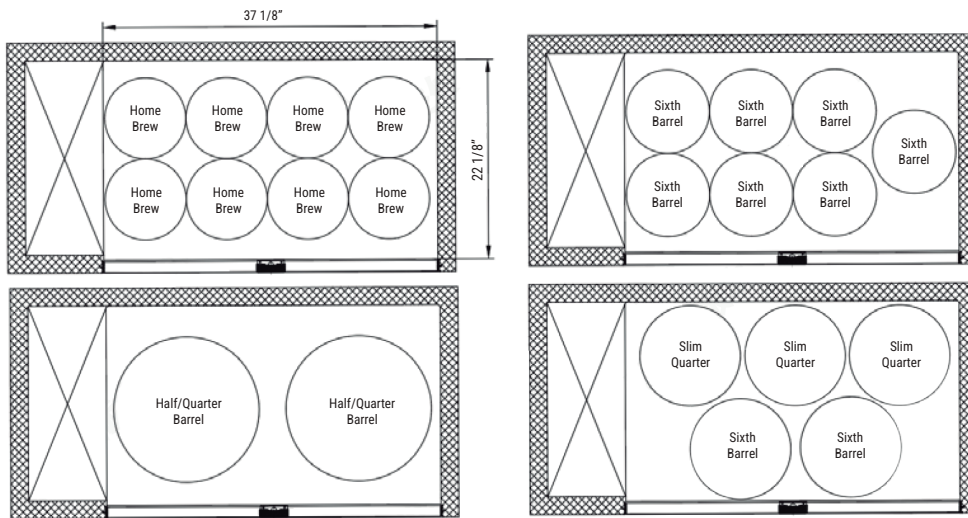

115/60/1
NEMA-5-15P



MODEL	EXTERNAL DIMENSION WXDXH (INCHES)	PACKAGING DIMENSION WXDXH (INCHES)	PRODUCT NET WEIGHT	40FT (PCS)
DKB48-M2	49 7/8"x27 3/4"x47 7/8"	58 4/8"x29 3/8"x42 1/8"	240 lbs	54

* All measures are presented in inches and pounds



Los Angeles | San Francisco | Dallas
Houston | Florida | Chicago | New Jersey

1-800-931-8628

@ info@dukersusa.com

www.DukersUSA.com