



# DUKERS

Quality Commercial Refrigeration



## KEGERATOR

MODEL DKB72-M3



### PRODUCT FEATURES



The Dukers draft beer system has ample space to withhold different keg of beers. Beer dispenses through a single tube with two handles made of stainless steel to ensure bacterial resistance.



Defrosts automatically to reduce ice buildup, and its evaporator coil is epoxy coated so it won't corrode. Designed with stainless steel construction, the top can be used as a durable workstation that's convenient to wipe clean



Equipped with electronic controls, users can adjust the temperature of the Dukers draft beer cooler from 33 to 38 degrees Fahrenheit.



Heavy-duty casters with brakes are included providing the unit with convenient mobility. Just roll the unit away from the wall.



Magnetic door gasket(s) standard for positive door seal



Beer Dispenser



Drip Tray



### TECHNICAL SPECIFICATIONS

Voltage/Frequency	110V/60Hz
Refrigerant	R290
Type of Defrost	Automatic
Interior Material	Stainless Steel
Exterior Material	Stainless Steel
Temperature Range °F	33 ~ 38°
Compressor Power (HP)	1/4+
Nema Config.	NEMA5-15P



### HIGH QUALITY STAINLESS STEEL & ROBUST DESIGN



# DUKERS

Los Angeles | San Francisco | Dallas  
Houston | Florida | Chicago | New Jersey

1-800-931-8628

@ info@dukersusa.com

www.DukersUSA.com

# DETAILS & SPECIFICATIONS

## KEGERATOR

Front View

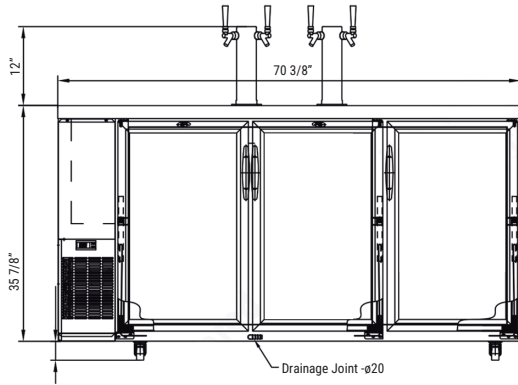

Side View

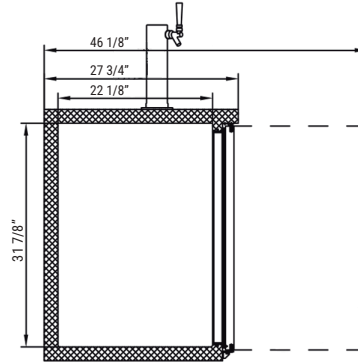

Top View

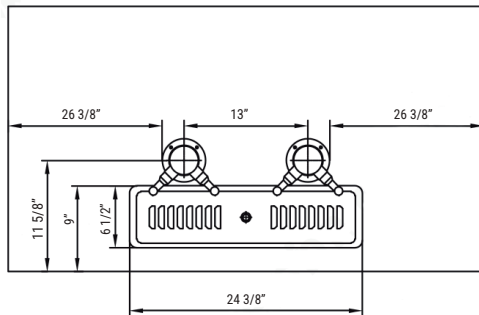

Keg configuration

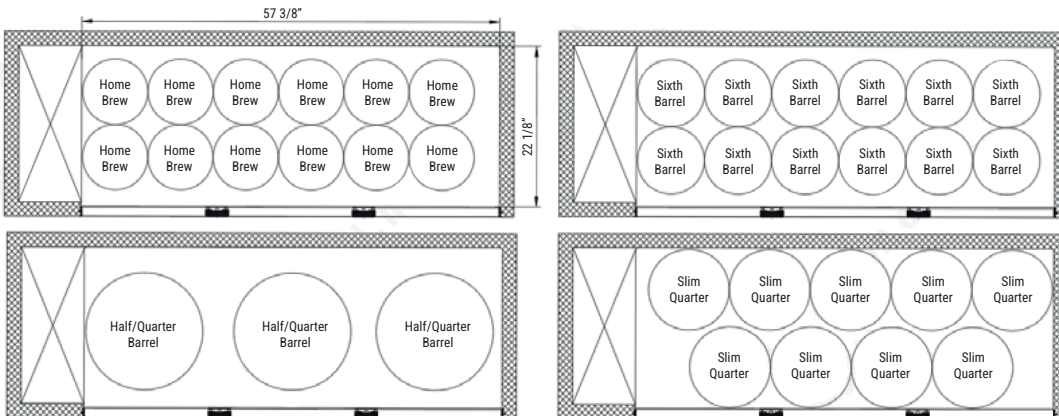

MODEL	EXTERNAL DIMENSION WXDXH (INCHES)	PACKAGING DIMENSION WXDXH (INCHES)	PRODUCT NET WEIGHT	40FT (PCS)
DKB72-M3	70 3/8"x27 3/4"x47 7/8"	72"x29 3/8"x42 1/8"	330 lbs	38

\* All measures are presented in inches and pounds



Los Angeles | San Francisco | Dallas  
Houston | Florida | Chicago | New Jersey

1-800-931-8628

@ info@dukersusa.com

www.DukersUSA.com